

• Description

This high performance NDIR CO2 sensor is designed specifically for the applications in the wide range of temperatures. The single light source and dual beam design with the intelligent software provides the excellent performance in linearity, environmental dependency, selectivity, stability, sensitivity, and life time of the sensor. It is ideal for automotive airflow control, air quality monitoring, HVAC and other CO2 management systems.

• Performance Characteristics

Output Mode:	UART, PWM
No. of Channel:	Dual
Dimension:	60 mm x 20 mm x 14 mm
Application:	Automotive, HVAC, Air Quality

• Environmental

Storage Temperature:	-40°C ~ 85°C
Working Temperature:	-40°C ~ 85°C
Working Humidity:	0% ~ 95%RH non-condensing

• Pinout

Pin 1 - TTL TXD	Pin 4 - GND
Pin 2 - TTL RXD	Pin 5 - +5 VCC
Pin 3 - PWM Output	

• Installation Instructions

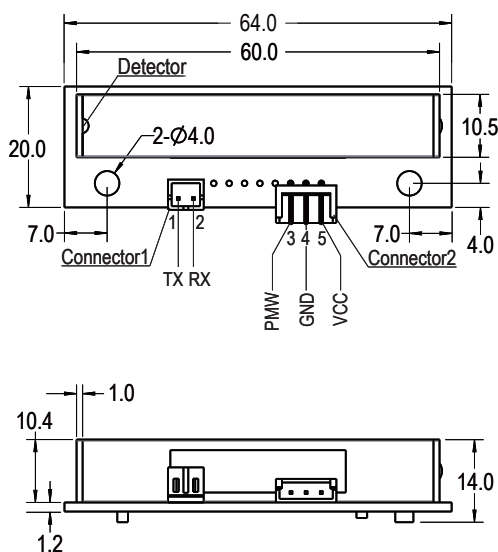

• Product Dimensions

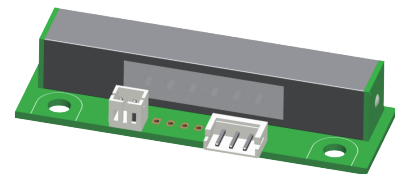
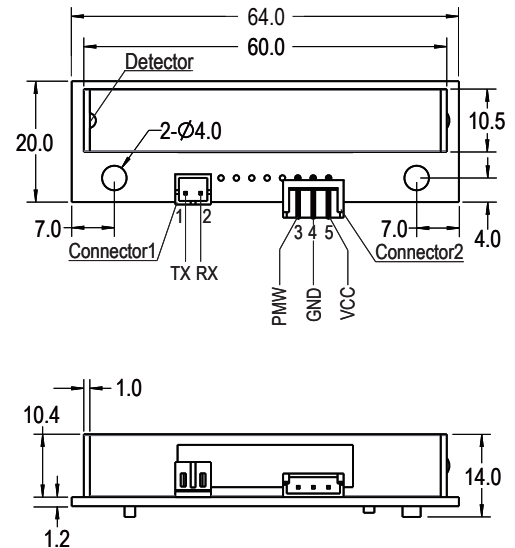

All dimensions in mm
All tolerances ± 0.20 mm unless otherwise stated

• Note

All the above performance parameters are measured in a standard test environment. Please contact us if you need more details.

• Technical Data

Description	Parameter	Unit
Detection Range	400 ~ 4,000 (Max: 10,000)	ppm
Detection Accuracy	@ -40°C ±150 ppm ± 5% reading, or ±75 ppm ± 5% reading for special order (-10 ~ 60°C) ±50 ppm ± 5% reading (customizable) @ 85°C ±150 ppm ± 5% reading, or ±75 ppm ± 5% reading for special order	
Response Time (T90)	< 2	minutes
Warm-Up Time	Start to Work < 30	seconds
	Precision Reached < 5	minutes
Working Voltage	5 ± 0.5	V
Working Current	Iavg: 80	mA

• PWM Output

Output Cycle: 1,004ms ± 5%

Cppm = 4,000ppm x (TH - 2ms) / (TH + TL - 4ms)

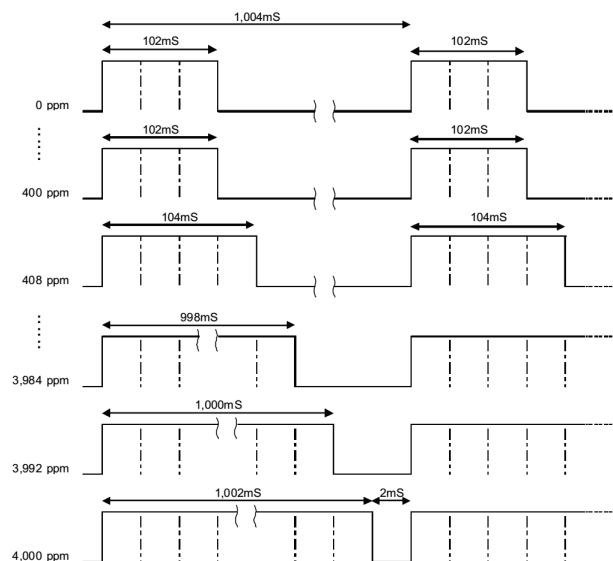

• UART Protocol

Baud Rate: 19,200 bps, 8 data bits, 1 stop bit, no check bit. The concentration readout and return data are in hexadecimal.

Concentration uploaded automatically in ASCII with the format:

32	32	x	x	x	x	x	32	p	p	m	\r	\n
----	----	---	---	---	---	---	----	---	---	---	----	----

For example: output of 12,345 ppm:

		1	2	3	4	5		p	p	m
0x20,	0x20,	0x31,	0x32,	0x33,	0x34,	0x35,	0x20,	0x70,	0x70,	0x6d,