

### • Description

This mini-Gamma sensor uses a 4x4x8mm Cesium Iodine (CsI) scintillator that uses a radiation-sensitive crystal as the detection component. It works with a PIN diode to convert the radiation to electric outputs. Along with a high sensitive preamplifier, the CsI crystal and PIN diode are encapsulated into a 18.2x12.2x6.4mm metal enclosure. This compact mechanical design enables the sensor to be used in small digital devices such as smart phones, smart watches and other wearable devices used for those who are sensitive to radiation.

This mini-Gamma sensor can be used to detect X-ray and Gamma ray with the energy from 30keV to 3MeV. The output of the sensor is half-gauss shaped pulse signal. The amplitude of output pulse is relevant to the energy of incident radiation particle. Below 1.2MeV of incident particle energy, the amplitude of output pulse is proportional to the energy of radiation particle. In addition the counting rate of output pulse is proportional to the radiation intensity of the measuring field as well. A voltage with a range from 2.0V to 5.5V can be used to power this mini-Gamma sensor. However, the applied voltage should come from stable DC power that has either minimal or no ripple because the DC power ripple couples with input terminal of the high sensitive preamplifier to form fault signals.

### • Specifications

|                                      |  |
|--------------------------------------|--|
| Measurable Range of X/γ Energy:      | 30 keV ~ 3 MeV   |
| Sensitivity (1μSv/h):                | > 4,000 pulse counts/h   |
| Energy Linearity:                    | 1 mV/keV (E < 1.2 MeV)   |
| Upper Limit of Measurable Dose Rate: | 0.5 mSv/h  |
| Operating Voltage:                   | DC 2.0 V ~ 5.5 V   |
| Static Current:                      | < 200 μA @ 3.3 V   |
| Working Temperature:                 | -20°C ~ 50°C   |
| Dimension:                           | 18.2 x 12.2 x 6.4 mm   |
| Weight:                              | 1.5 g  |
| Static Offset Level of Output:       | 850 mV ± 150 mV  |
| Wires:                               | 1-Red: Power V+<br>2-Black: V- or Ground<br>3-Green: Signal output |
|                                      | Solid wire diameter: 0.45 mm<br>Sleeve wire diameter: 0.80 mm      |
| Warranty:                            | 15 months  |

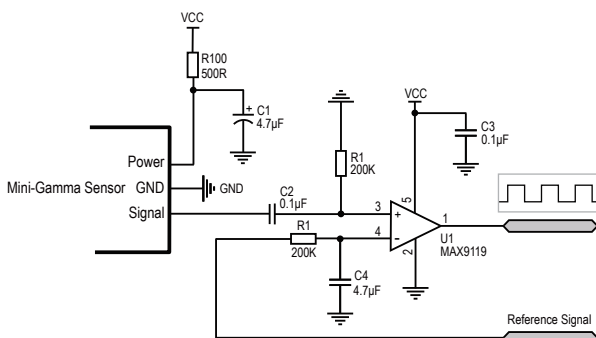

### • Product Dimensions

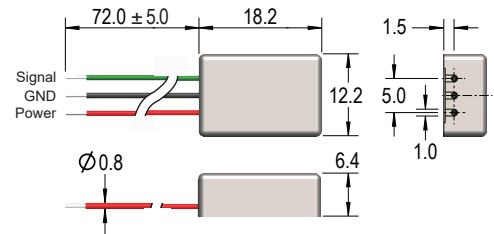

All dimensions in mm

All tolerances ±0.20mm unless otherwise stated

### • Application Example

The example here shows a radiation counting system. It mainly uses a mini-Gamma sensor to convert incident X/γ rays to electric pulses. In addition, it uses a comparator to discriminate noise pulses and uses a MCU to collect true radiation pulses to calculate radiation intensity. The recommended schemematic diagram is given below. The discriminator is designed with a comparator MAX9119.

A shape of a pulse output of the mini-Gamma sensor is shown below:

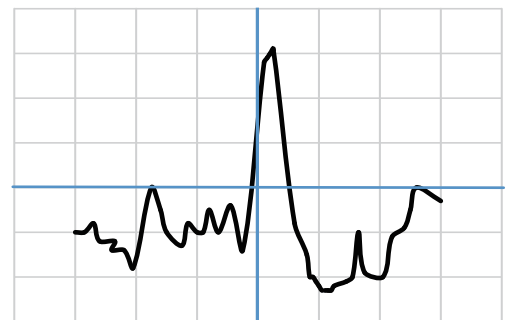

Oscilloscope setting:  
Vertical 50mV/div  
Horizontal 50μs/div

Gamma ray energy:  
59.9keV from Am241 source